



FICHA TÉCNICA

ENNOVABLOC 25°

PIEZA	NOMBRE	MATERIAL	PESO
	EnnovaBloc 25°	Hormigón	64 kg
	Unión Terminal	Aluminio AW-6005	0,038 kg
	Unión Intermedia	Aluminio AW-6005	0,039 kg
	Espuma Protectora 1200 x 150 x 3	Espuma de Polietileno Rugosa	0,028 kg



Importante:

Siga siempre las instrucciones de montaje de Ennova.
www.ennovarenovables.com



COTAS

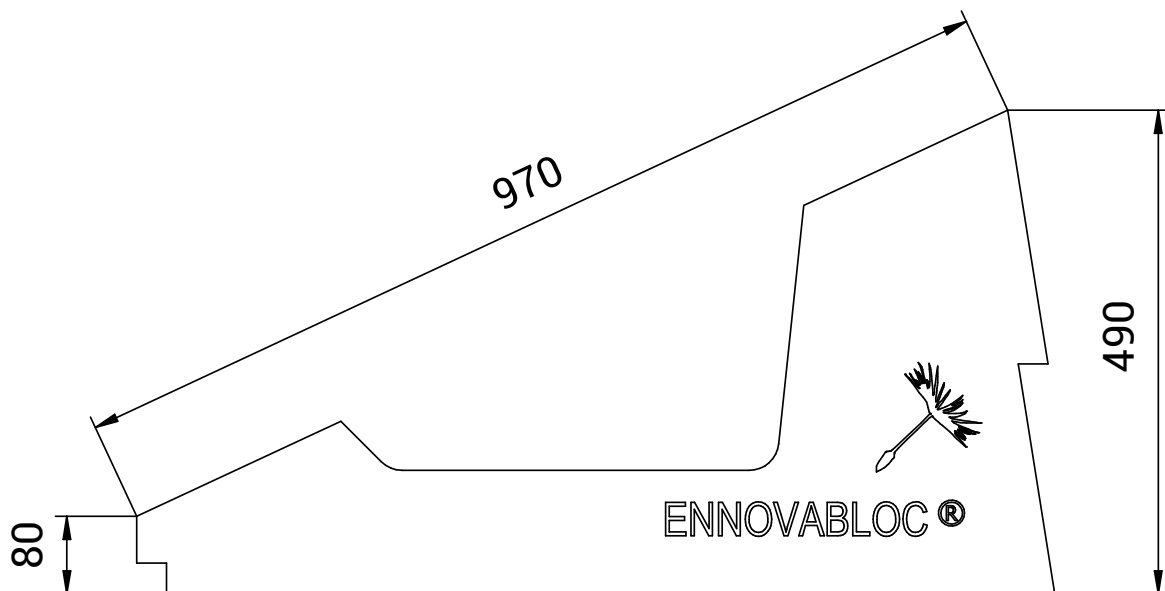
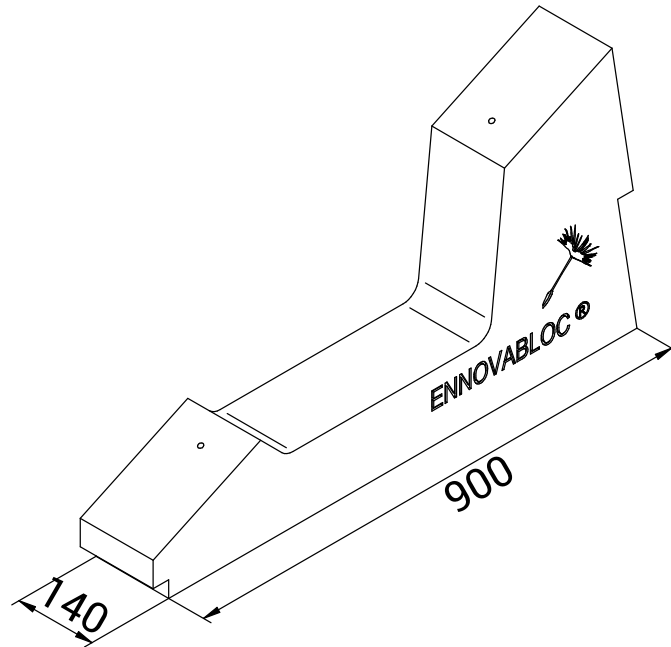

Importante:

Siga siempre las instrucciones de montaje de Ennova.
www.ennovarenovables.com